

Thermaco
BIG DIPPER® *Kitchen Grease Removal*

Installation & Operation Instructions
For the Big Dipper W-250-AST-E
Automatic Solids Transfer (AST-E) Series Unit

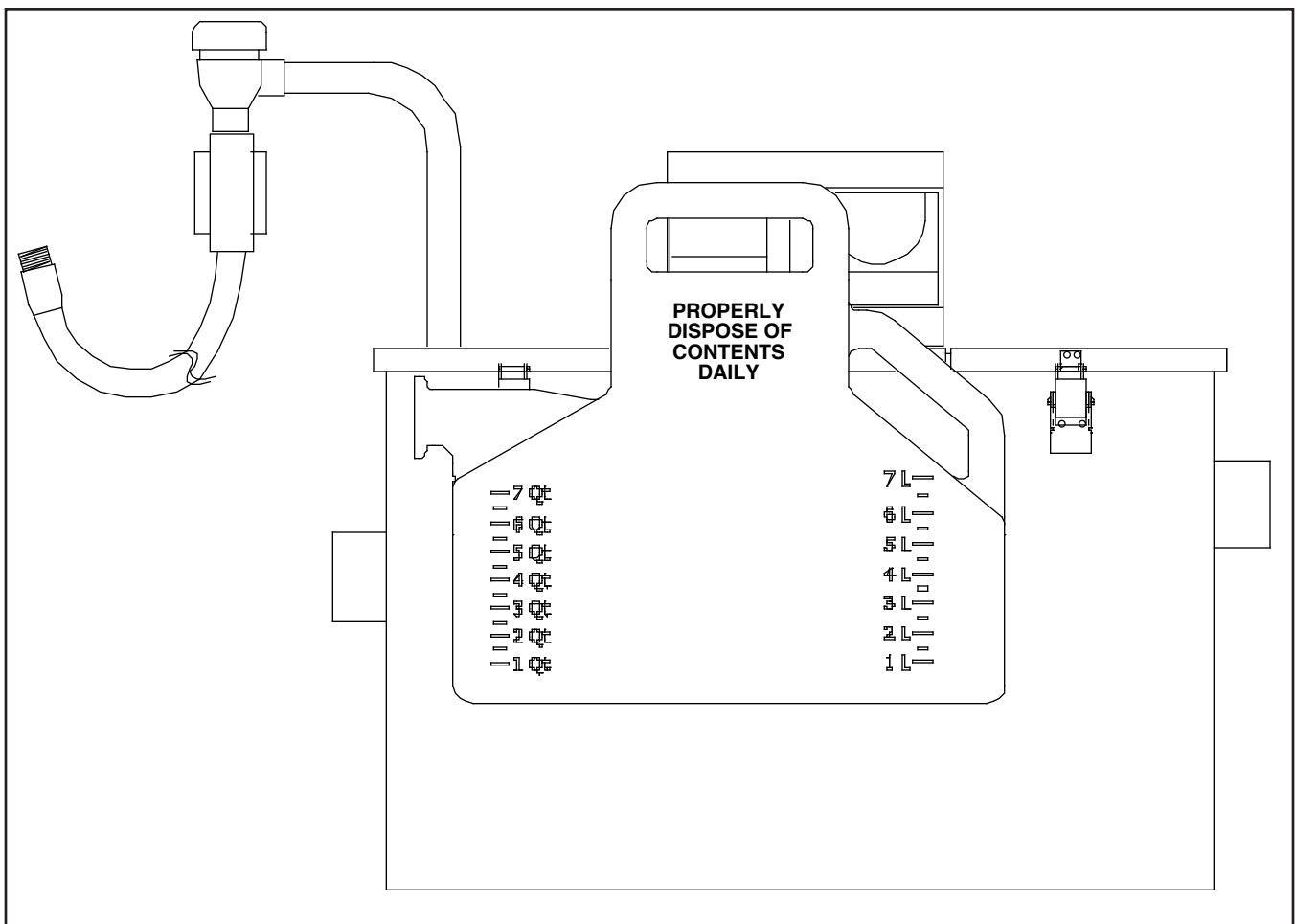

Copyright ©2007 Big Dipper® Thermaco, Inc. • P.O. Box 2548 • Asheboro, NC 27204
Toll Free: (800) 633-4204 • V: (336) 629-4651 • F: (336) 626-5739
E-mail: info@thermaco.com • Online: www.big-dipper.com



BIG DIPPER[®]

Table of Contents

Table of Contents

AST System Overview	3
AST System Maintenance	4
AST Timer Operation	5
AST System Troubleshooting	6
How To Reverse AST System Operation	7
Plumbing Installation	8
Electrical Installation	10
AST Module Wiring Diagram	11
AST Component Identification	12
AST Replacement Parts	13
Limited Warranty	14



BIG DIPPER®

Big Dipper® Automatic Solids Transfer (AST) System Overview

The **Thermaco, Inc. Big Dipper®** Automatic Grease and Oils Removal System removes free-floating grease & oils from kitchen drain water flows. As most food service facility managers already know, grease buildup within a building's plumbing drainage system is a major cause of problems due to drain line blockages. These problems jeopardize normal operations as well as create health and safety hazards within the facility itself.

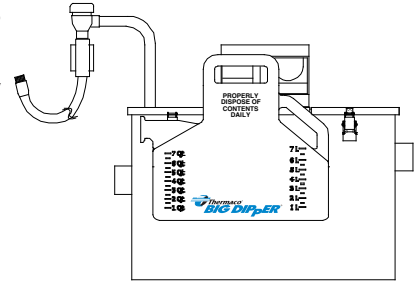

The proper installation of a Big Dipper System can reduce or eliminate grease problems. Use of the Big Dipper assures minimization and/or elimination of costly sewer surcharges and fines through efficient separation and removal of free-floating grease & oils. In addition, the Big Dipper also helps reduce or eliminate pumping and disposal costs associated with conventional grease traps or interceptors. The recovered grease & oils are substantially water-free and are suitable for recycling by local rendering and/or biodiesel companies.

The Big Dipper system is an automatic, self-cleaning device. As greasy kitchen effluent drains from kitchen fixtures, the unit traps the grease & oils. These separate from the effluent and rise to the surface of the separator tank. The unit automatically skims the trapped grease & oils and transfers the grease & oils to a collection container. A timer controls the self cleaning operation, activating the skimming wheel at a user-set time. Only the "cleaned" water exits the unit and flows into the facility drain lines.

Incidental food solids less than 1" (25 mm) in diameter are separated and flushed out of the system automatically by the Automatic Solids Transfer component. These incidental solids are typical of those that are rinsed off of plates before going to a dishwasher. The Eductor Pump of the AST is not designed to handle non-food products such as plastic, rubber or metal items.

The Big Dipper system's compact footprint allows installation directly at the source, where grease problems originate. The system design also allows easy maintenance and operation requiring only a minimal amount of daily and weekly maintenance to maintain peak operating performance.

The Big Dipper system design allows for maximum installation flexibility. Reversing the system operation is as simple as rotating the cover assembly of the unit.

Grease interceptors, grease traps, automatic recovery units, grease removal devices and other similar plumbing devices receiving kitchen flows from sinks, floor drains, woks and other food bearing sources may generate odors. There are many factors influencing odor evolution and dissemination. These include room ventilation, kitchen menu, ambient temperatures, ware washing practices, grease/oil input, daily input fluid volume, sanitizers, installation plumbing design and product maintenance/upkeep. Odors are usually prevented by good area ventilation, frequent fluid inputs, good product maintenance practices and proper product installation. Additional steps, including aeration, chlorination, improved area ventilation and additional maintenance control, may be needed at some sites.



BIG DIPPER[®]

Big Dipper[®] Automatic Solids Transfer (AST) System Maintenance

Big Dipper[®] Automatic Solids Transfer (AST) System Maintenance

***CAUTION! DISCONNECT POWER TO UNIT BEFORE CLEANING OR SERVICING to prevent damage to the unit and personal injury**

***NOTE: Before energizing unit after cleaning, fill tank with water to protect wipers and heater from damage**

Daily Maintenance:

(A) Empty the clear plastic grease/oils collection container (located beside the unit) prior to its becoming full once each day. The Big Dipper recovers grease and oil virtually water-free so that they can be recycled. The collector container should be washed periodically so as to maintain the easy viewing translucent characteristic of the collector.

Weekly Maintenance:

(A) Check the collection trough and the wiper blades for any solids build-up. Wipe off any accumulated deposits and assure the wiper blades are clipped in place properly.

(B) Check the Timer to be sure it is set and operating correctly.

(C) Remove & spray down the strainer assembly to remove any accumulated solids. Be sure to spray down both the inside and outside surfaces of the strainer assembly.

(D) Check the thickness of the grease layer at the top of the unit. If there is more than a 1/2" (12 mm) thick layer of grease after the skimming cycle, this indicates a need to increase the skimming time. Increase the timer settings accordingly until a clean unit appearance is obtained after the automatic skimming cycle (A simple guide is to increase the "on" time by 30 minutes for each 1" (25 mm) of grease layer observed after the skimming cycle).

Quarterly Maintenance:

The internal strainer assembly in the unit is designed to remove incidental solids from the wastewater. Over a period of time, sediment consisting of very fine particles may begin to accumulate on the bottom of the unit. If this build-up is allowed to continue, it may eventually block the outlet baffle. To prevent this from occurring, remove the lid and stir the bottom of the unit with a long handled spatula while water is flowing to flush out the sediment. Occasionally drain and clean the unit thoroughly. Properly used, a wet vac may be appropriate for this purpose.

Big Dipper® AST System Suggested Settings/Timer Operation

TO SET TIMER:

1. Push on/off tabs on the outer ring of timer inward into dial at desired "ON" times. 1 Tab = 15 minutes. Minimum of one (1) tab (15 minutes) **not to exceed 2 hours in a complete run cycle.**

2. Turn dial **CLOCKWISE** one or more complete revolutions until the present time is aligned with the time-of-day indicator point.

3. Fill the unit with water by turning on the sink water taps, then plug the Big Dipper unit into grounded electrical outlet.

4. Tabs pushed IN = ON
Tabs pushed OUT = OFF

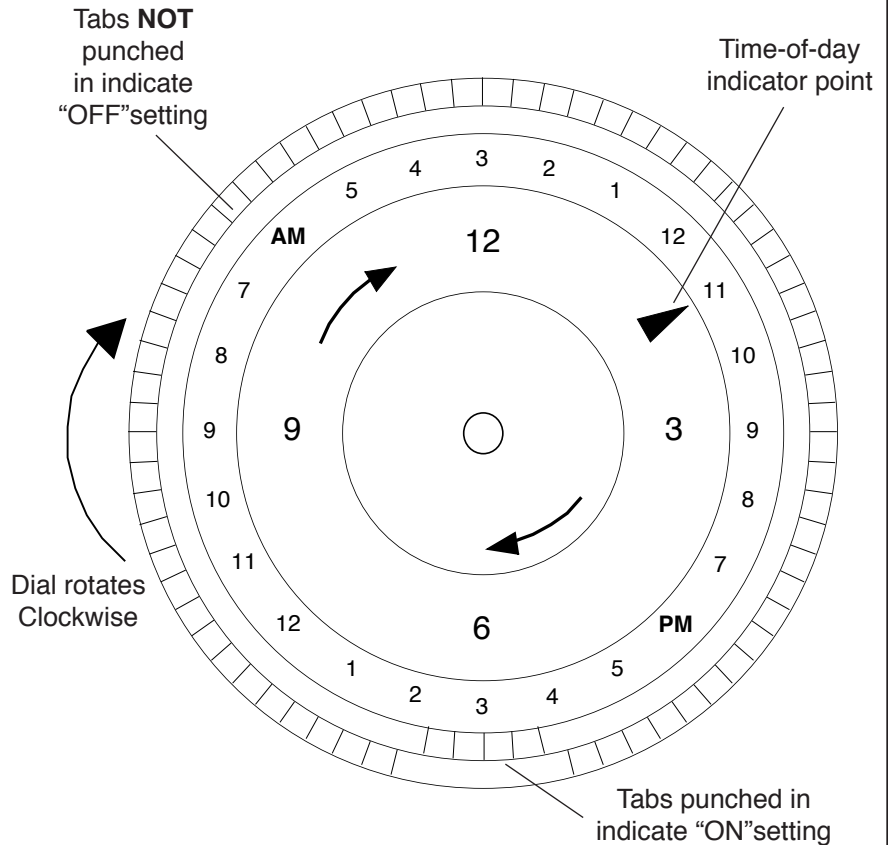

NOTE: IN CASE OF POWER FAILURE, RESET TIMER. (See Step 2 above).

After the plumbing installation is complete, the Big Dipper unit needs to be set for the proper automatic self-cleaning operation for the facility. The Big Dipper W-250-AST model is equipped with one (1) 24 Hour/96 Event time controller. The time controller is located under the lid of the motor housing mounted on top of the Big Dipper lid (See Pages labeled "Electrical Connection Detail" sketches of this location).

Depending upon the amount of accumulated grease and oils, the system may need to be reset to operate more or less time to skim all separated grease and oils. This can be determined by removing the top cover and observing the depth of the separated grease layer shortly after a cleaning cycle is completed. This layer should not be more than 1/2" (12 mm) thick. If this layer is consistently thicker, increase the operating times of the Big Dipper AST System by 30 minutes for each additional 1" (25 mm) of grease **not to exceed 2 hours in a complete run cycle.** If required, additional run cycles can be added throughout the day. Consequently, if there is any quantity of water in the grease collector, then the Big Dipper is operating too long. Decrease the amount of operating time by one tab (15 min.) at a time until no water is collected in the container.



Big Dipper® AST System Series Troubleshooting

Big Dipper unit overflows

(1) Check to see that the outlet pipe is not reduced to a smaller size, the outlet piping is vented, has as few 90 degree outlet turns as possible, and that no "P" trap is installed on the outlet. Re-plumb the piping, if necessary. Check outlet piping for clogs. Have a plumber clean the line, if necessary.

2) Make sure that the solids collection chamber is free of excessive debris. To check Eductor Pump operation, unplug the unit for 10 seconds, then re-energize. The Eductor Pump should automatically activate.

3) Check the bottom of the grease chamber for excessive solids and silt buildup which may be blocking the outlet baffle. Disconnect the power and use a long handled spatula or similar instrument to stir the bottom while water flows through the unit. If necessary, drain and clean the sediment from the unit. To prevent recurrence, schedule this cleaning to be done on a regular basis (properly used, a wet vac may be appropriate for cleaning sediment from the bottom of the unit).

4) Make sure the flow rate to the unit does not exceed the maximum flow rate, which is shown on the nameplate. If necessary, have a plumber install an approved flow control to restrict the inlet flow to the specified level or install a properly sized Big Dipper for the application.

Excessive water observed in the grease collection container

1) Check Timer for excessive "on" time. Unit will pick up incidental water after all grease is removed.

2) Make sure that the water flow to the unit does not exceed the rated flow and there are no drain line clogs downstream from the unit.

No grease is collected in the container

(1) Check to be sure the power is on and the time control is set correctly. The "on" time should be no less than 15 minutes per day.

(2) Remove the lid and clean away any buildup that may be present on the wiper blades or collection trough. Make sure the wiper blade(s) are properly in place on the skimmer wheels. Replace wiper blades when worn or warped.

(3) Set the time control to the "ON" position & ensure that the skimmer turns. CAUTION: Keep your hands away from moving parts to avoid possible injury. If the skimmer motor does not come on, the motor assembly must be replaced.

(4) Check for congealed grease in the unit. If the Big Dipper's heating element is not warming the unit, the heating element must be replaced.

(5) Some sites do not generate enough grease to be captured by the skimming process. Set Timer for minimum operation - 1 Tab (15 Min.)

Objectionable odor

(1) Make sure grease/oil is being skimmed properly from the unit.

(2) Check the timer settings for excessive "on" time. Also check to see if any water is collected in the grease collector. Reduce operating time until water is no longer observed in the grease collector.

(3) If excessive sediment has collected on the bottom of the unit, clean the unit as described in item 3 in "Big Dipper unit overflows."

(4) Clean the solids strainer assembly and grease collection container more frequently.

(5) Grease interceptors, grease traps, automatic recovery units, grease removal devices and other similar plumbing devices receiving kitchen flows from sinks, floor drains, woks and other food bearing sources may generate odors. There are many factors influencing odor evolution and dissemination. These include room ventilation, kitchen menu, ambient temperatures, ware washing practices, grease/oil input, daily input fluid volume, sanitizers, installation plumbing design and product maintenance/upkeep. Odors are usually prevented by good area ventilation, frequent fluid inputs, good product maintenance practices and proper product installation. Additional steps, including aeration, chlorination, improved area ventilation and additional maintenance control, may be needed at some sites.

How To Reverse Big Dipper® AST System Unit Operation

***ALWAYS UNPLUG UNIT BEFORE REMOVING LID**
***SYSTEM WILL NOT OPERATE UNLESS CENTER MODULE IS IN PLACE**

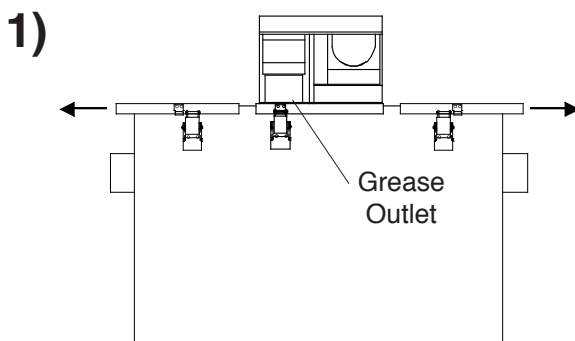

1) Unlatch the Unit lid. Pull the side wings outward.

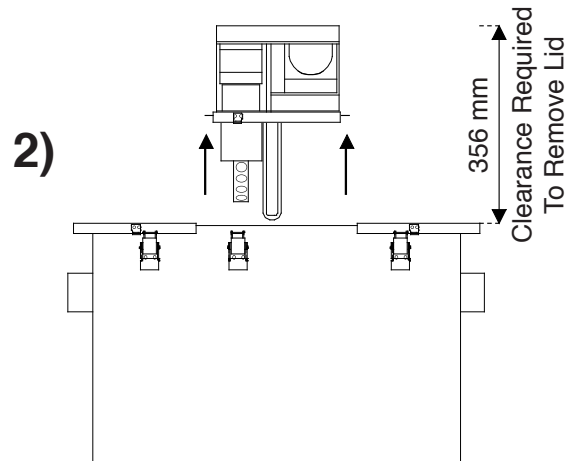

2) Lift the center module up off of the unit, ensuring clearance for the heater.

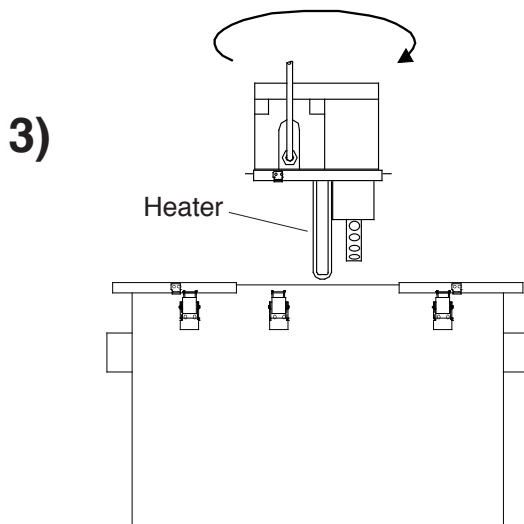

3) Rotate the center module 180°.

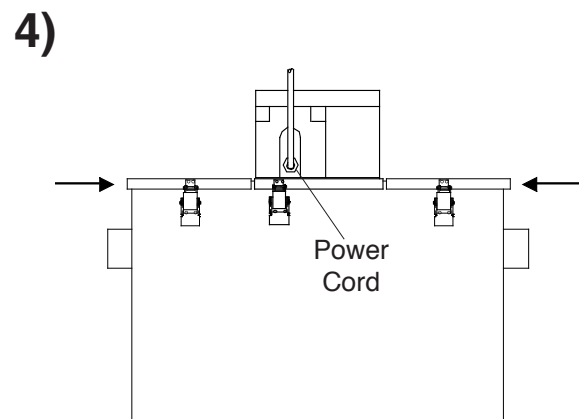

4) Lower the center module back down on top of the unit. Move the two side wings back into place & fasten all latches.



BIG DIPPER®

**Big Dipper® AST System
Plumbing Installation**

Big Dipper® AST System Plumbing Installation

Locating The AST Unit

To minimize grease build-up in piping, a Big Dipper system should be located as close as possible to the fixture it is serving. The system should be visible and easily accessible for maintenance and inspection. The unit must be in a level position. **Be sure to check the Specification Sheet for your model for the exact clearances needed for installation.** If the system is located directly on the floor, the bottom should be sealed to the floor with an approved silicone type sealant. Make sure the height above the Solids Strainer access cover is enough to remove the strainer assembly.

Eductor Pump

The facility must provide a minimum 3.45 Bar water supply to the Eductor pump on the AST system. Thermaco, Inc. provides a 19 mm Garden Hose Style Connector to connect to this water supply. The eductor pump on the W-250-AST-E is designed to handle incidental food solids of less than 1" (25 mm) in diameter. Non-food products including plastic and metal parts cannot be removed by the Eductor. The W-250-AST-E requires at least 0.32 l/s flow for proper operation.

Inlet/Outlet Piping

The inlet and outlet piping connections require no-hub type connectors. Keep outlet piping as straight as possible. Assure that outlet pipe has at least a slope of 1/4" per foot. Use only "sweep" connections. Don't reduce the pipe

sizing on the outlet piping. Don't install "P" trap on outlet connection of system. (Note: The system already has a internal gas trap)

Flow Controls

Big Dipper systems are equipped with an internal flow regulator located inside the inlet end of the system. Verify its location and placement prior to connecting the inlet piping. If your code requires a vertical type flow regulator, an approved control with a flow rating matching the system's flow rate should be used. Note: When a Big Dipper is servicing multiple fixtures, some codes require separate flow controls for each fixture. See following page for suggested high head height flow regulation installation.

Fill Unit With Water Before Applying Power

Big Dipper systems equipped with an electric heating element MUST be filled with water before energizing the power to the system. Failure to do so will result in the destruction of the electric heating element. These elements will NOT be replaced under Thermaco's Warranty.

Venting The Outlet

An outlet vent or approved air admittance valve of at least 1/2 the diameter of the system's outlet connection must be present within two (2) feet of the Big Dipper outlet to prevent possible siphoning problems. Failure to provide a vent for the system voids Thermaco's Warranty.

Do Not Use With Food Grinders, Potato Peelers or Waste Disposal Units

If the system is connected to a Food Disposal or Garbage Grinder, Thermaco's Warranty will be void.

Note: Drawing for reference only. Equipment must be installed in compliance with all applicable laws, regulations and codes, including plumbing codes. Installation should be performed by a qualified plumber.

Big Dipper® AST System Plumbing Installation (For Installations With Head Height Greater Than 6 feet (1.95m))

For installations where there is a significant amount of head height (More than 6 ft./1.95 m), Thermaco, Inc. recommends installation of the optional VFCA Vented Flow Control module.

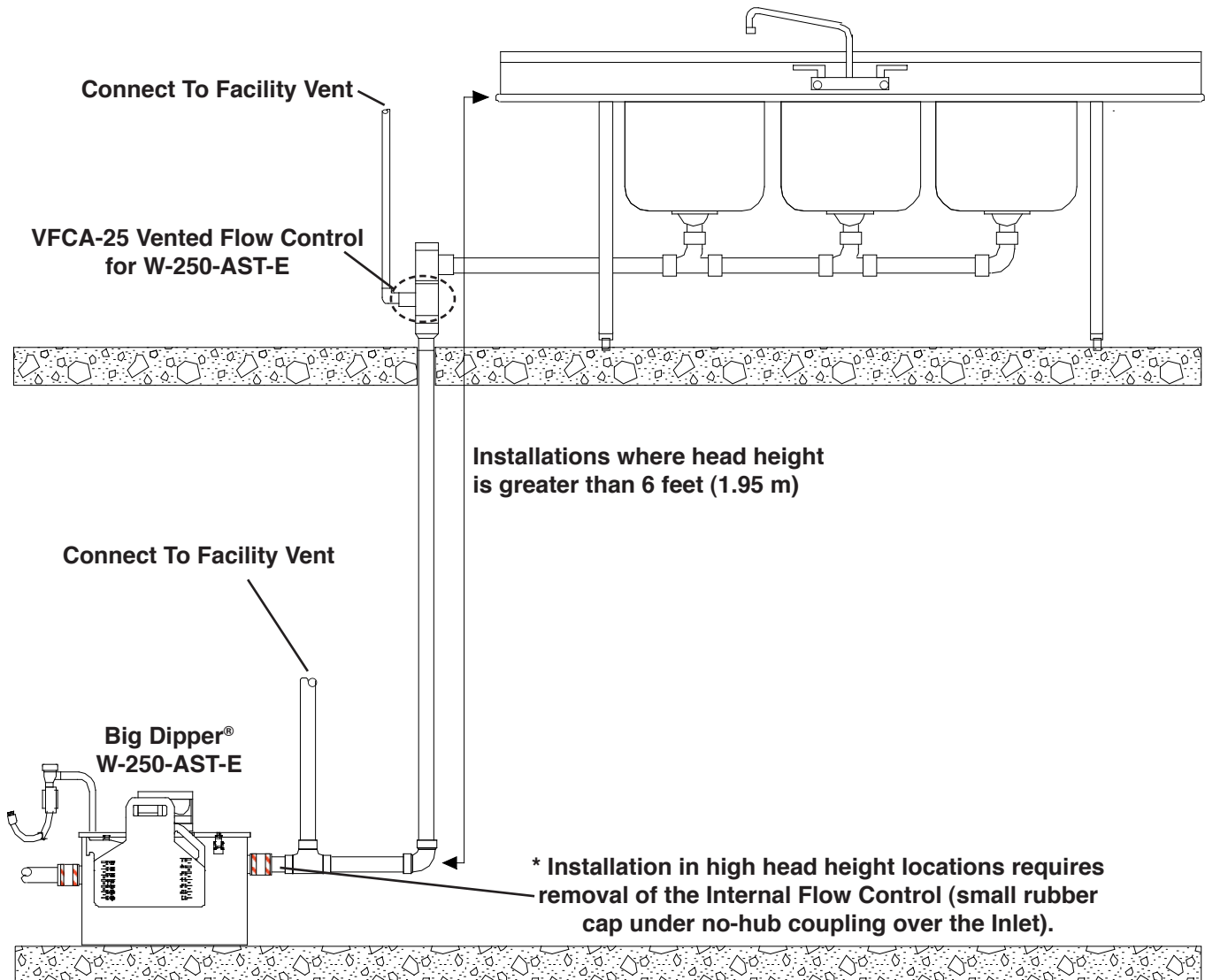

Note: Drawing for reference only. Equipment must be installed in compliance with all applicable laws, regulations and codes, including plumbing codes. Installation should be performed by a qualified plumber.

Big Dipper® AST System Electrical Installation

Big Dipper Automatic Solids Transfer (AST)

The Big Dipper W-250-AST-E model is equipped with one (1) 24 Hour/96 Event time controller. The timer is located under the hinged lid of the motor enclosure on top of the lid of Big Dipper (See Timer Operation Instructions). **The Big Dipper should only be plugged into a properly grounded 220-240VAC outlet.** If possible, the power supply outlet for the Big Dipper should be connected to an electrical circuit controlled by a ground fault circuit breaker.

This Big Dipper unit is shipped from the Factory wired for **Simultaneous Operation**. This means the Heater and Motor operate at the same time under timer control. **Continuous Heater Operation** is where the Heater is active at all times. To switch to **Continuous Heater Operation**, switch the RED WIRE on the THERMOSTAT with the BLACK WIRE. (Instructions are on the wiring Diagram in the electrical enclosure.

Note: The Big Dipper unit will not operate when the electrical module is removed.

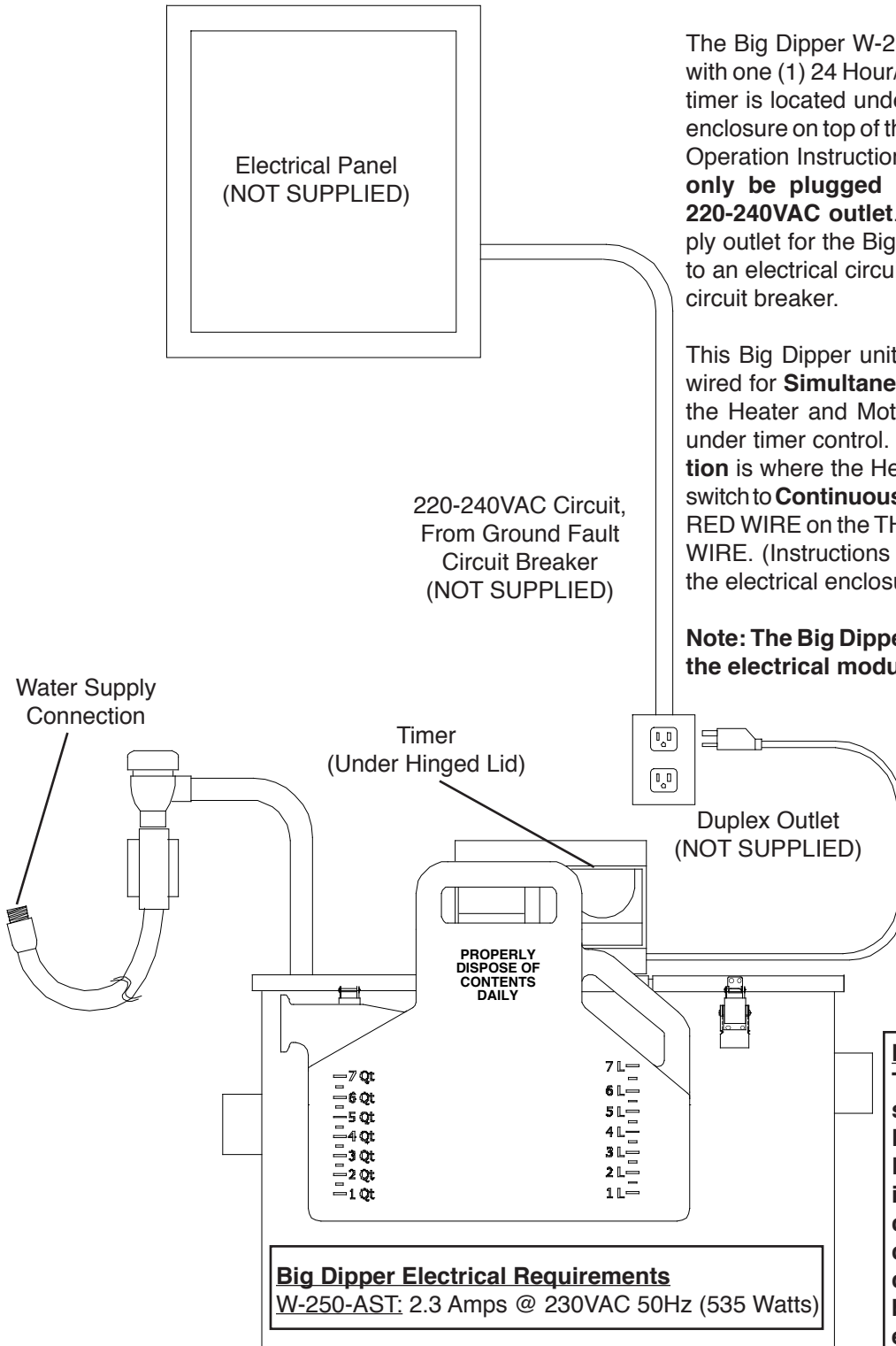

Note:
Time Clock Supplied with system.
Drawing for reference only. Equipment must be installed in compliance with all applicable laws, regulations and codes, including electrical codes. Installation should be performed by a qualified electrician.

Wiring Diagram For Big Dipper® Model W-250-AST

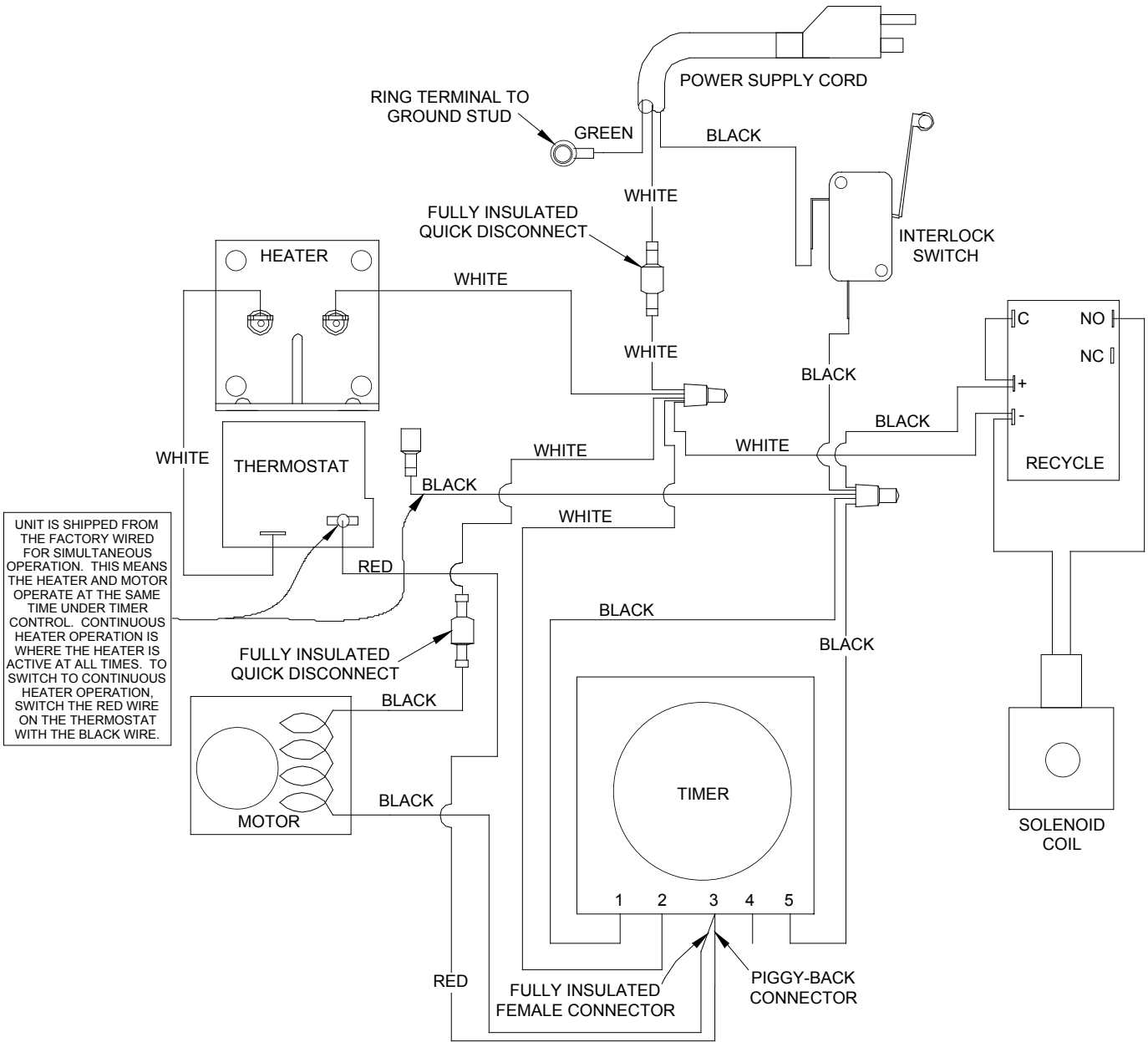

UNIT IS SHIPPED FROM THE FACTORY WIRED FOR SIMULTANEOUS OPERATION. THIS MEANS THE HEATER AND MOTOR OPERATE AT THE SAME TIME UNDER TIMER CONTROL. CONTINUOUS HEATER OPERATION IS WHERE THE HEATER IS ACTIVE AT ALL TIMES. TO SWITCH TO CONTINUOUS HEATER OPERATION, SWITCH THE RED WIRE ON THE THERMOSTAT WITH THE BLACK WIRE.

NOTE:
220-240V Units (International Units) have the following wire color changes:
On the POWER SUPPLY CORD:
The Black Wire becomes Brown
The White Wire becomes Blue
The Green Wire becomes Yellow/Green

Big Dipper AST Lid Components (With Covers In Place)

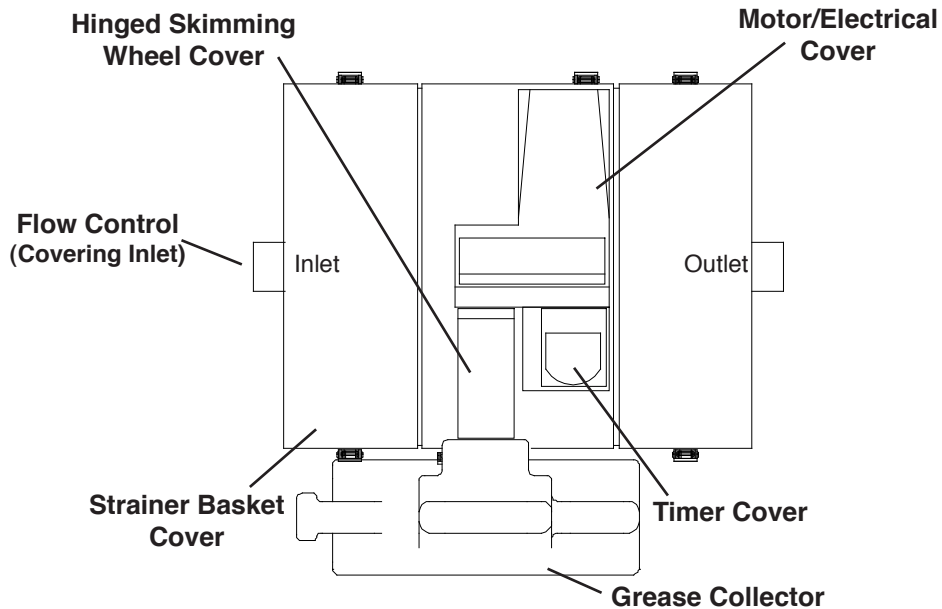

Big Dipper AST Lid Components (With Wheel Cover Removed)

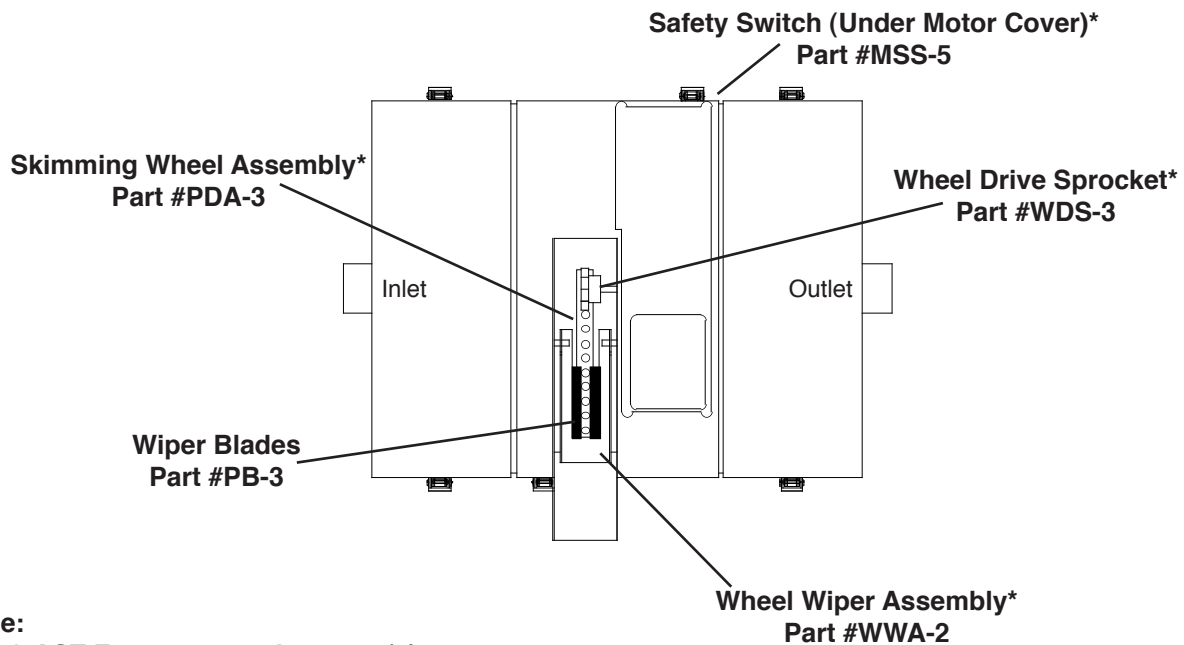

***Note:**
W-250-AST-E system requires one (1)

Big Dipper® AST System Replacement Parts

STRAINER ASSEMBLY

FOR MODEL#

USE PART#

W-250-AST-E

BA-250-AST

TIMER (Under Cover)*

FOR ALL MODELS USE PART# ETC-2-E

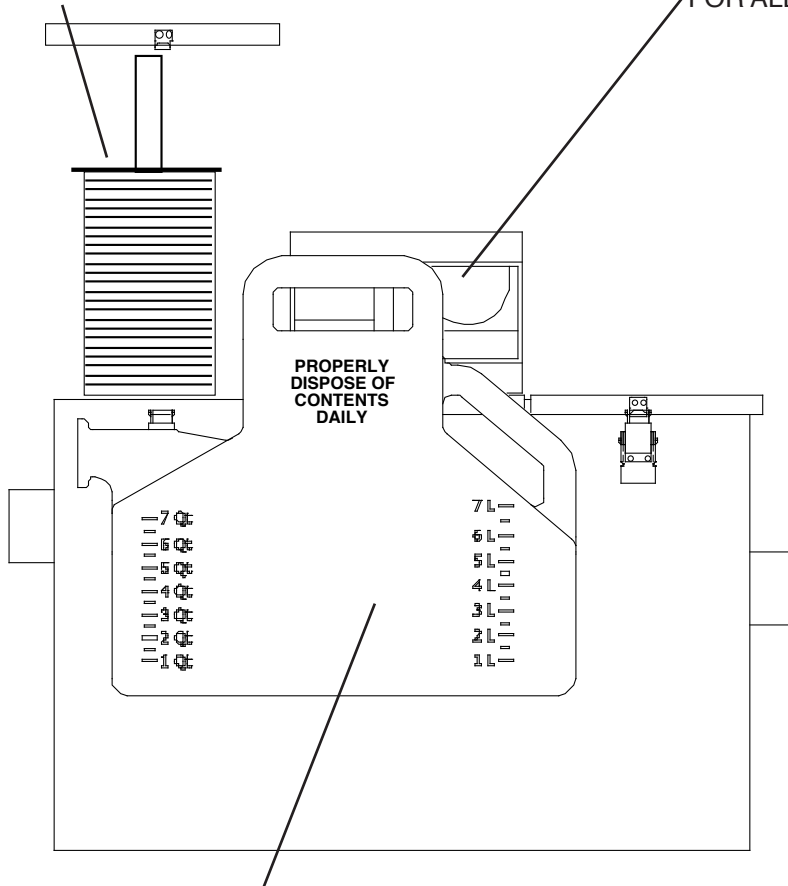

NOT SHOWN:

MOTOR*

PART# M-58-230

HEATER*

PART# H-7-230

THERMOSTAT*

PART# TSTAT-4

INTERNAL FLOW CONTROL

PART #MFC-25 FOR W-250-AST-E

LID GASKET

PART# RG-7

WIPER BLADES

PART# PB-3

• W-250-AST-E requires two (2)

WHEEL WIPER ASSEMBLY*

PART# WWA-2

WHEEL DRIVE SPROCKET*

PART# WDS-3

SKIMMING WHEEL ASSEMBLY*

PART# PDA-3

ATMOSPHERIC VACUUM BREAKER

PART# VB-AST-12

EDUCTOR PUMP SOLENOID COIL

PART# SCOIL-240

EDUCTOR PUMP SOLENOID VALVE

PART# SOL-AST-230

GREASE/OILS COLLECTION CONTAINER*

FOR W-250-AST-E USE PART# GC-7

***Note:**

W-250-AST-E system requires one (1)



BIG DIPPER[®]

Big Dipper[®] Limited Warranty & Remedy

Thermaco, Inc. warrants to the original user that the products manufactured by it delivered with this warranty shall be free from material defects in workmanship and materials for a period of 12 months from the date of invoice to the distributor (if sold by an authorized Thermaco distributor) or the date of invoice to the purchaser (if sold directly by Thermaco, Inc.), but in no event longer than 15 months from date of shipment from Thermaco's production facility.

Any claim must be made in writing to Thermaco at 646 Greensboro Street, Asheboro, NC 27203 promptly after discovery of the defect and within the applicable warranty period. The product must be delivered, prepaid, to Thermaco, together with proof of purchase, the serial number from which the item was removed and a return authorization number issued by Thermaco. If Thermaco determines upon examination that the component is defective and that the warranty conditions are met, Thermaco's sole obligation under this warranty, and the purchaser's sole and exclusive remedy, is the repair or replacement, at Thermaco's option, of the defective component, including parts and labor. The replacement will be furnished F.O.B. point of shipment. If Thermaco determines that the component is not defective or that the other conditions of this warranty are not met, then any return of such part to the purchaser shall be at purchaser's cost.

This warranty shall not cover any defect in otherwise covered products resulting directly or indirectly from: (i) failure to properly install, operate or maintain the product in accordance with Thermaco's instructions and procedures, including, without limitation, use in excess of rated flow, operation without timer control, improper electrical service, use to remove emulsified fats and oils or use that fails to comply with applicable laws, regulations or codes; (ii) damage in transit, handling or installation; (iii) modifications, adjustments, repairs, or alterations made by unauthorized persons; or (iv) other causes not arising out of defects in workmanship or materials. Thermaco shall not be responsible for damage to products resulting from vault flooding, sewer line back-up, pumping or lift station failure, ambient water flow or other sources of water damage. This warranty does not cover equipment or parts not manufactured by Thermaco. Purchaser's costs relating to any service, adjustment, removal, repair, packing, or otherwise incurred with respect to the defect prior to submission for warranty are the responsibility of purchaser.

No distributor, sales person or other person is authorized to make any warranty statements on behalf of Thermaco regarding Thermaco products other than as set forth in this warranty. This statement of warranty supersedes any quote, brochure, or other statement or document with respect to warranty of Thermaco products.

EXCEPT AS EXPRESSLY SET FORTH ABOVE, THERMACO, INC. MAKES NO REPRESENTATIONS, WARRANTIES OR GUARANTEES, EITHER EXPRESSED OR IMPLIED, INCLUDING, WITHOUT LIMITATION, AS TO **MERCHANTABILITY OR FITNESS FOR A PARTICULAR PURPOSE**, WHETHER OR NOT THERMACO HAD KNOWLEDGE OF PURCHASER'S PARTICULAR REQUIREMENTS OR NEEDS, OR WITH RESPECT TO ODOR GENERATION OR OTHER INCIDENTALS RELATING TO USE OF THE PRODUCT.

The sole and exclusive remedy with respect to this warranty any other claim relating to defects or any other condition or use of Thermaco products, however caused, and whether such claim is based upon warranty, contract, tort, strict liability or any other theory, is LIMITED to the repair or replacement of the product, excluding labor or any other cost to remove or install said the product or, at Thermaco's option, repayment of the purchase price. IN NO EVENT SHALL THERMACO, INC. BE LIABLE, WHETHER IN CONTRACT, WARRANTY, TORT (INCLUDING NEGLIGENCE), STRICT LIABILITY, INDEMNITY OR ANY OTHER LEGAL THEORY, FOR INCIDENTAL OR CONSEQUENTIAL DAMAGES, OR FOR ANY OTHER LOSS OR COST OF A SIMILAR TYPE. UNDER NO CIRCUMSTANCES WILL THE AGGREGATE LIABILITY OF THERMACO FOR ANY CAUSE OF ACTION RELATED TO THE PRODUCTS COVERED HEREBY EXCEED THE NET PURCHASE PRICE RECEIVED BY THERMACO FOR THE PRODUCTS. Any action or suit by purchaser against Thermaco relating to Thermaco products must be brought within one (1) year of the date of the invoices referenced above. The exclusions and limitations set forth herein are separate and independent from any remedies which purchaser may have hereunder and shall be given full force and effect whether or not any or all such remedies shall be deemed to have failed of their essential purpose.