

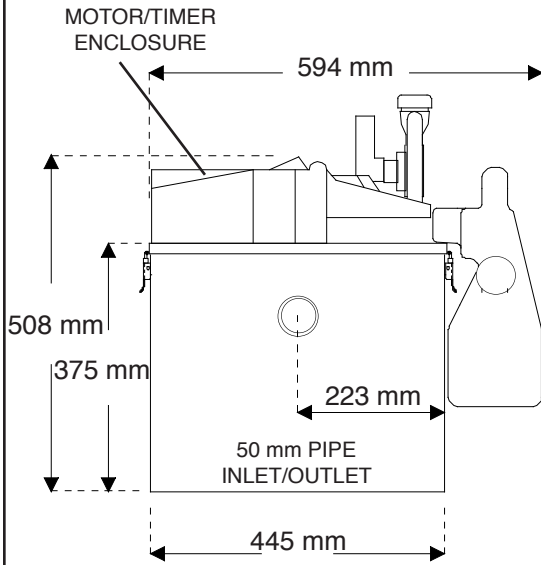

Big Dipper® AST Point Source Automatic Grease Removal Systems

W-250-AST-E Specifications



END VIEW

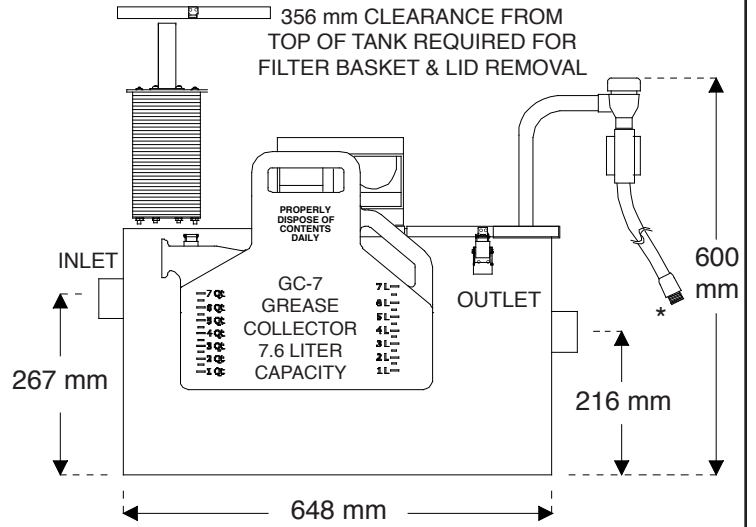

SIDE VIEW

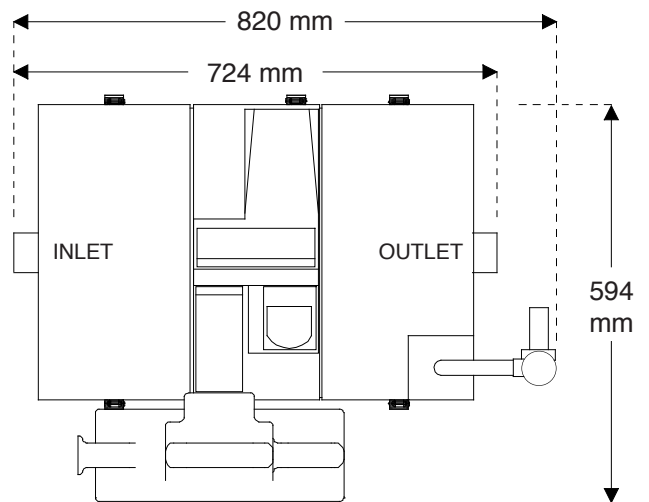

TOP VIEW

FEATURES:

- Fully automatic self cleaning cycle. Removes collected grease, oils and solids from unit without any operator assistance. Comes complete with 24-hour timer.
- Constructed of corrosion resistant materials suitable for installation in virtually any location. Attractive sanitary Stainless Steel exterior.
- Integrated Motor/Grease Outlet/Heater/Lid enables a fast, do-it-yourself unit operation reversal.
- Easy lift grease collector simplifies grease collection container emptying.
- Compact footprint.

* Unit supplied with 915 mm Hose & 19 mm GH Female Connection to Connect to Facility-Supplied Water Supply

TECHNICAL DATA

Materials:	Exterior: 304 Stainless Steel, Bright Finish
	Interior: Rotationally Molded Polyethylene
Electrical:	220-240 VAC, 50 Hz, 535 Watts (2.3 Amps)
Maximum Inlet Flow Rate:	1.6 l/s
Number of Skimming Wheels:	1
Skimming Rate:	9.08 Kg Per Hour
Grease Retention Capacity:	22.7+ Kg
Eductor Pump Operation Water Requirements:	3.45 Bar min., 0.32 l/s



**Big Dipper® AST Point Source
Automatic Grease Removal Systems
W-250-AST-E Specifications**

INSTALLATION INFORMATION

DO...

Suggested Minimum Footprint Dimensions

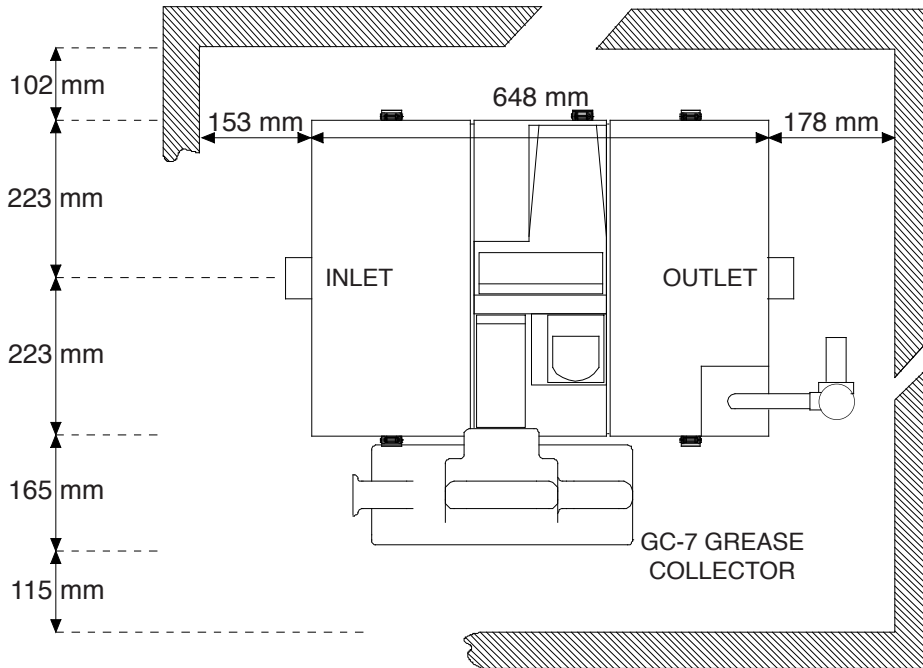

Allow minimum of 356mm clearance from top of tank for removal of unit lid.

READ instruction manual included with system before doing anything.

Install unit allowing for the minimum clearances shown.

Provide a min. 3.45 Bar, 0.32 l/s Water Supply for solids pump operation

Make sure the height above the Internal Strainer Access Cover is enough to remove the strainer.

Make piping connections with rubber "No Hub" connectors.

Keep outlet piping as straight as possible. Use only "sweep" connections.

Install vent on outlet piping.

Fill the tank with water before energizing the power to the motor and heater.

Set Programmable Time Controller for proper operating times.

DON'T . . . Install "P" trap on outlet connection of tank. (Note: the unit already has an internal gas trap). Reduce pipe size on outlet piping.

NOTE: Drawing for reference only. Equipment must be installed in compliance with all applicable laws, regulations and codes, including plumbing codes. Installation should be performed by a qualified plumber.

Job Specification:

Grease and oils separator(s) shall be Thermaco **Big Dipper** automatic grease/oil recovery system(s) with Automatic Solids Transfer as manufactured by Thermaco, Inc., Asheboro, North Carolina as noted on plans.

Separator Specifications:

Furnish and install ___ Thermaco **Big Dipper** Model No. W-250-AST-E, bright finish type 304 stainless steel exterior, rotationally molded polyethylene interior automatic self-cleaning grease and oil recovery separator(s) for floor mounted or partially recessed installation, rated at 1.6 l/s peak flow, 22.7 Kilograms of grease capacity and including as an integral part of the unit, 1 rotating gear hydrophobic wheel assembly for automatic grease/oil removal, an integral flow control device, self-regulating enclosed electric immersion heater, a vessel vent, an integral gas trap, an integral programmable 24-hour multi-event time control, a field reversible motor location, a field reversible grease/oil sump outlet, quick release stainless steel lid clamps, a gasketed and fully removable 304 stainless steel lid, lift-out filter basket access, an eductor transfer pump controlled by repeat cycle timer, and a separate grease and oils collection container. Eductor pump shall be supplied with 915 mm Hose & 19 mm GH Female Connection for attachment to facility-supplied water supply. Eductor pump shall be supplied with an approved vacuum breaker. Electric assembly shall be tested to comply with pertinent sections of the Standards for Safety ANSI/UL 73 and/or ANSI/UL 1004. Electric motor shall be equipped with thermal overload protection with automatically resettable switch.